

### PARTS LIST

ITEM	PART NO.	DESCRIPTION	REQ'D.
1	12303	HOUSING	1
2	12231	1/2" O.D. RING GASKET	1
3	10515	SCREW	1
4	10627	CAM	1
5	4432	DRIVE KEY	1
6	9959	IMPELLER	1
7	4258	RET. RING	3
8	12314	MECH. SEAL	1
9	12256	SEAL SEAT	1
10	4264	THRUST WASHER	1
11	12856	END PLATE	1
12	12328	BODY	1
13	12857	CAPSCREW	3
14	12710	LOCKWASHER	3
15	4259	RET. RING	2
16	12664	SHAFT	1
17	12211	BALL BEARING	2
18	5133	SPACER BEARING	1
19	12636	HUB	1
20	11543	PIN	1
21	12855	GASKET	1
22	13285	TAG	1

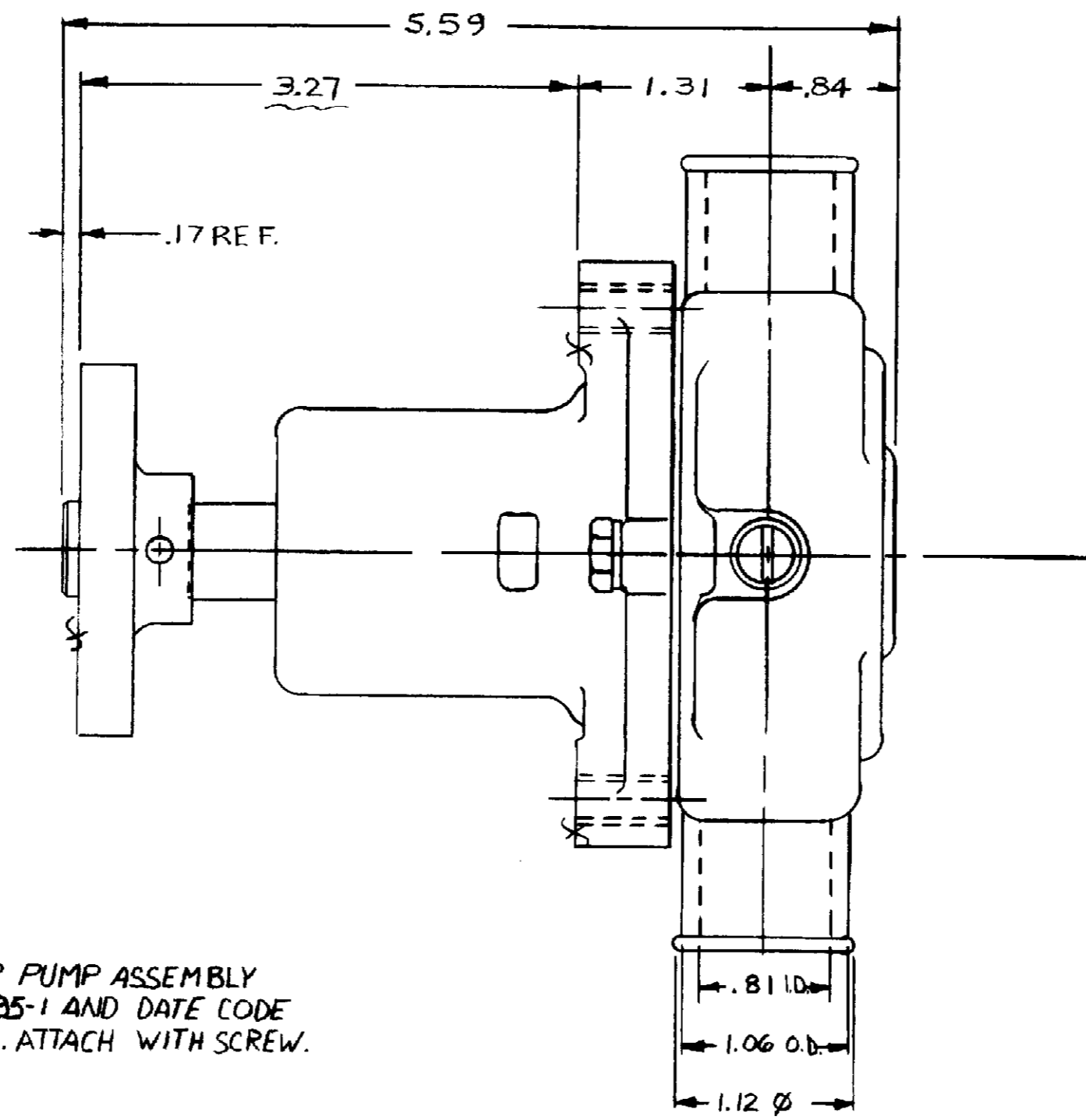

SERVICE ASSY NO.	COMPONENT ITEM NO'S	G95-1
(E) SEAL & SEAT ASSY NO. 12859	8 & 9	
MINOR SERVICE KIT #12399		
MAJOR SERVICE KIT #12665		

(D) PACKAGING:  
 11516 PALLET 1 REQ'D  
 14120 TUBE CONTAINER 1 REQ'D  
 14122 PADS 7 REQ'D  
 14124 INSERTS 5 REQ'D  
 36 PUMPS PER LAYER \* 5 LAYERS = 180 PUMPS PER PALLET

17659 CARTON  
 12209 LABEL WHEN QTY 1  
 14486 JIFFY BAG No. 4

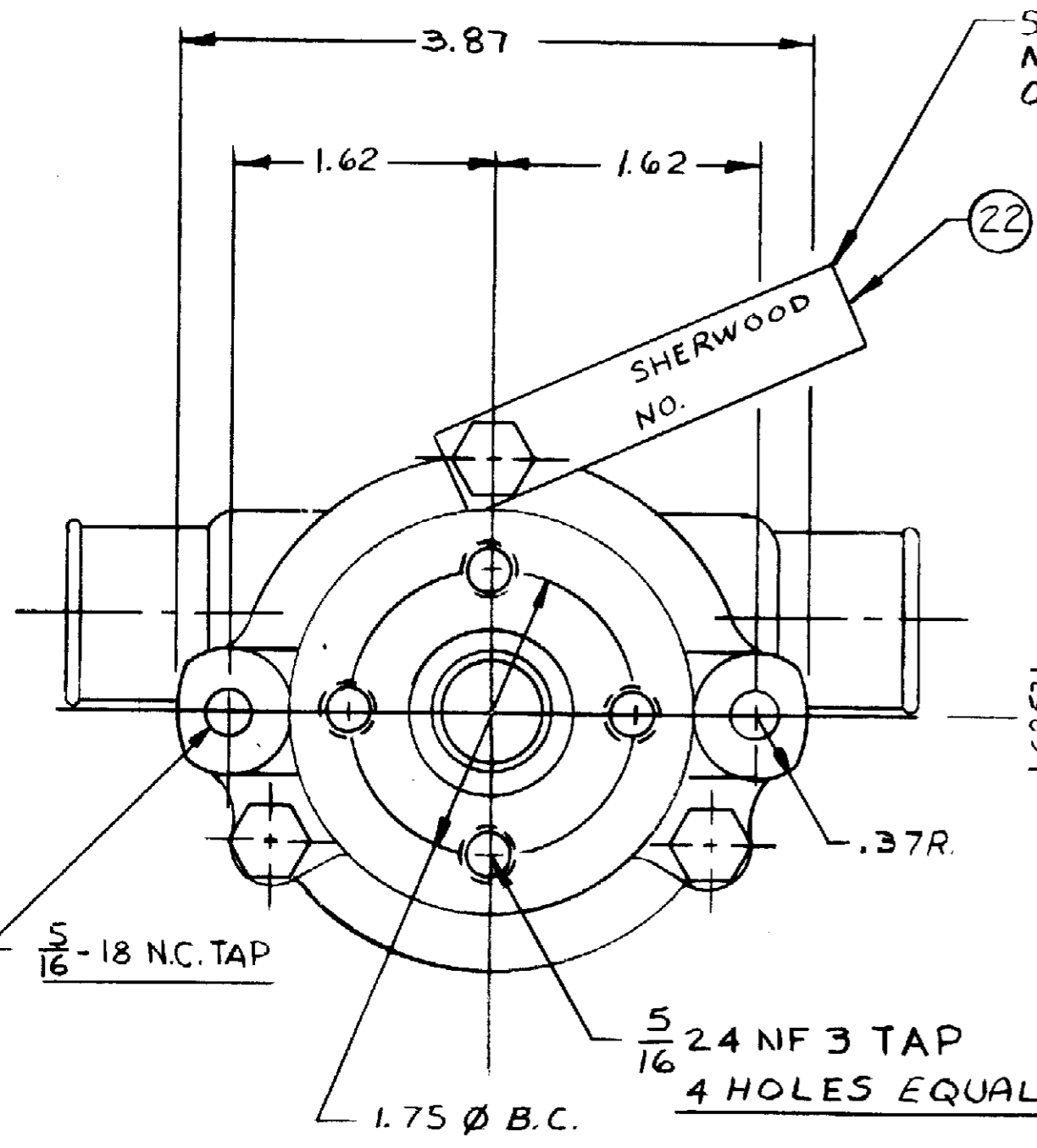

STAMP PUMP ASSEMBLY NO. 6-95-1 AND DATE CODE ON TAG. ATTACH WITH SCREW.

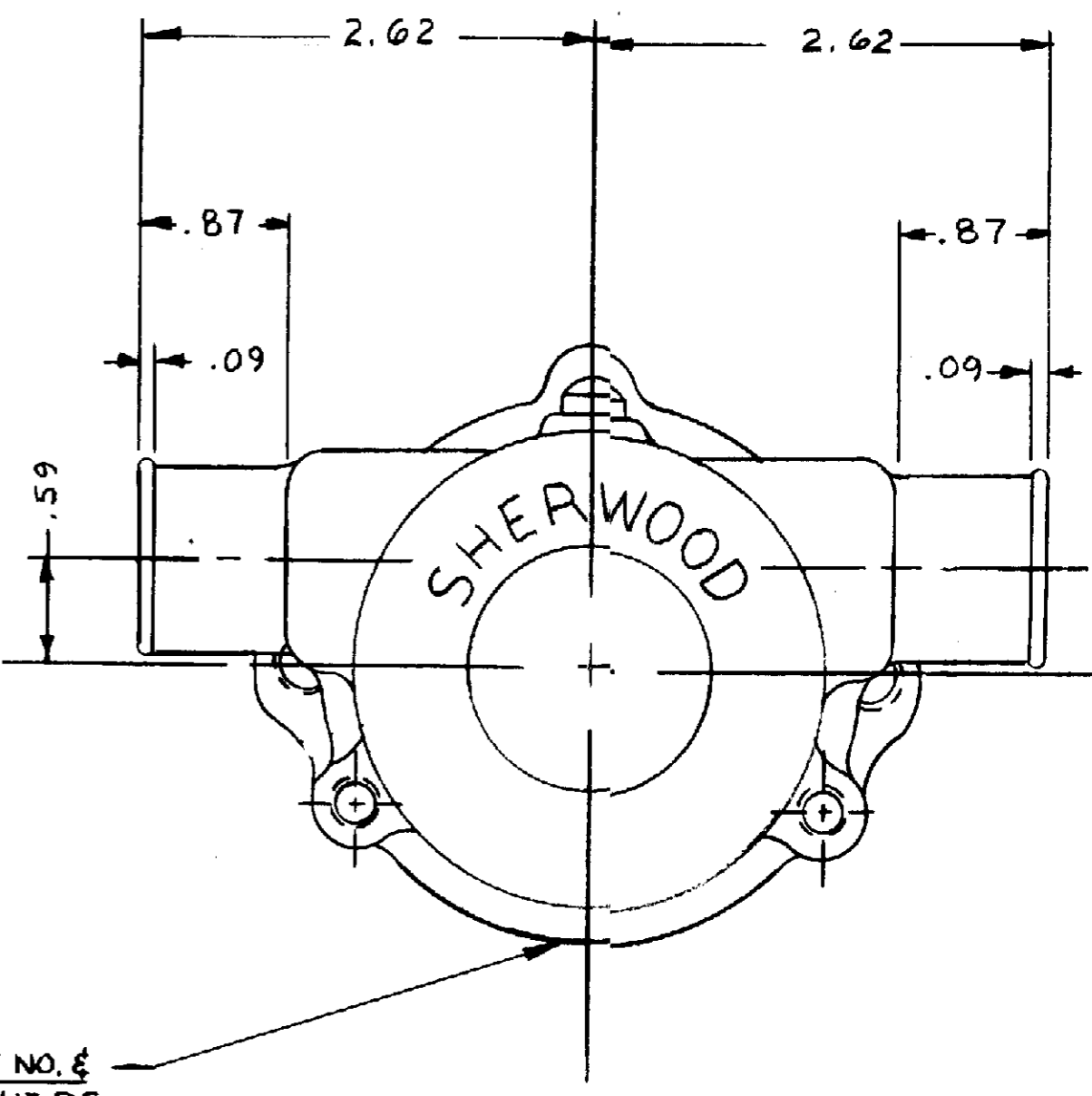
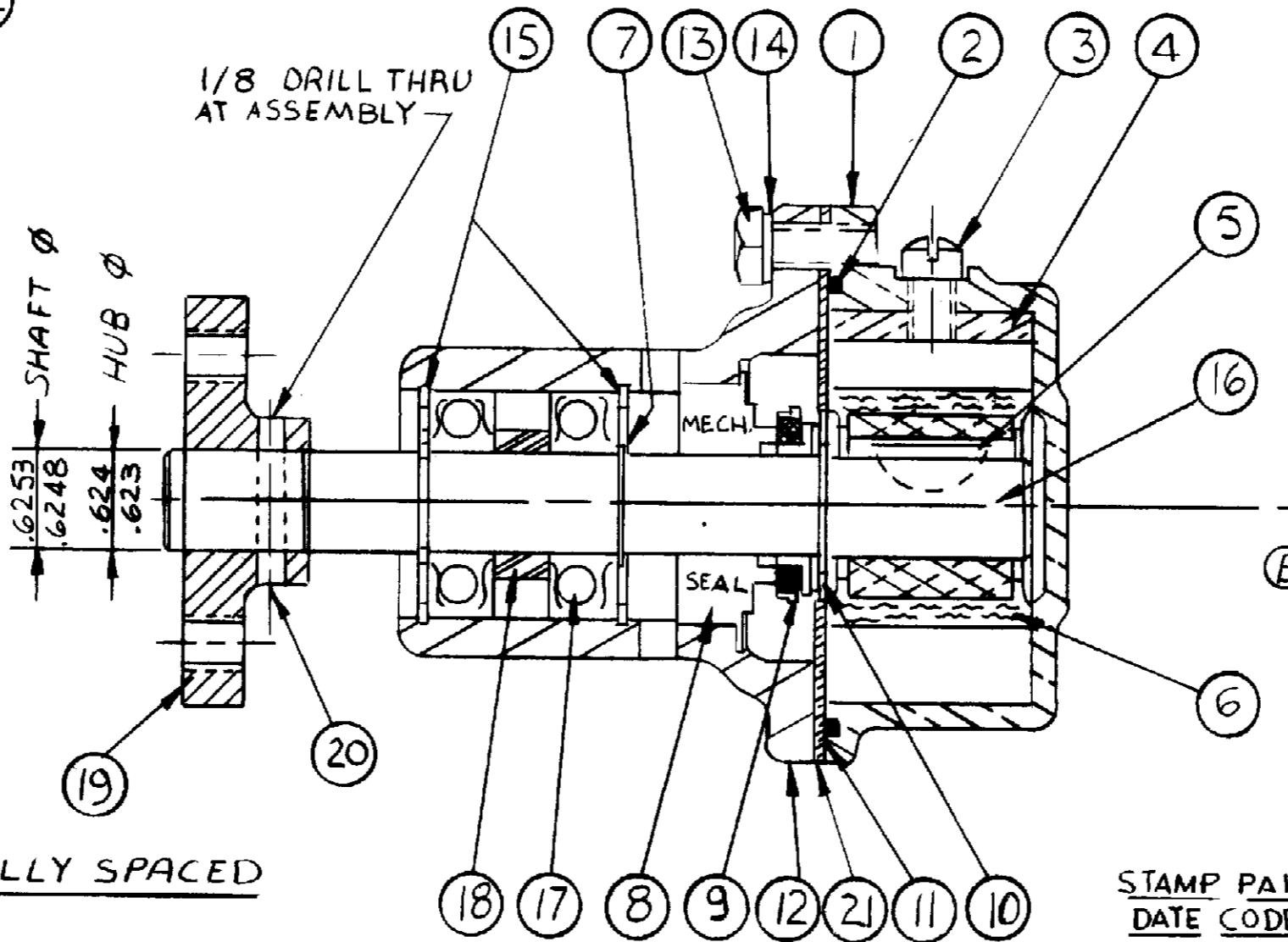

STAMP PART NO. & DATE CODE HERE

FLOW CURVE G-15

REV	DESCRIPTION	APPR	DATE
E	12859 WAS 12322	SH	7/5/90
D	PACKAGING NOTE ADDED	SH	9/11/89
C	12314 WAS 8388	SH	11-11-88
B	LOGO REVISED	SH	10-1-88
A	REDRAWN	KB	8-86

UNLESS OTHERWISE SPECIFIED:  
 CAST DIMENSIONS ± .02  
 FILLETS & RADII .06  
 FINISH STOCK .07  
 MACHINING TOLERANCE, INCHES  
 XX ± .01, XXX ± .005  
 SURFACE ROUGHNESS  
 ANGLES ± 0° 30'  
 CORNER BREAKS .01 MAX.

**SHERWOOD**  
 A DIVISION OF HYPRO CORPORATION  
 6331 E. JEFFERSON AVE. - DETROIT, MICHIGAN 48207

DRAFTSMAN: K.B. DATE: 8-86 CHECKER: DATE: ASSY NO.:  
 TITLE: PUMP ASSEMBLY - RUBBER IMPELLER  
 MATERIAL: SEE DETAILS DWG. NO.: G95-1