

PARTS LIST

ITEM	PART NO.	DESCRIPTION	REQ'D
1	13363	SHAFT	1
2	13795	HUB	1
3	4259	RET RING INT	2
4	12211	BEARING	2
5	5133	SPACER	1
6	12314	SEAL ASSY.	1
7	12256	SEAT ASSY.	1
8	13796	BODY (COATED)	1
9	12855	GASKET	1
10	12231	"O" RING	1
11	13899	HOUSING	1
12	12856	END PLATE	1
13	4264	THRUST WASHER	1
14	4258	RET. RING EXT.	3
15	4432	KEY-WOODRUFF	1
16	10615	IMPELLER	1
17	10929	CAM (.219)	1
18	10515	SCREW 1/4-20 X 3/8	1
19	12710	LOCK WASHER	3
20	13794	SCREW MG X 1.00 THD	3
21	13285	TAG - PART NUMBER	1
22	12859	SEAL & SEAT ASS'Y	SERVICE
23	12946	MAJOR REPAIR KIT	SERVICE
24	12394	MINOR REPAIR KIT	SERVICE

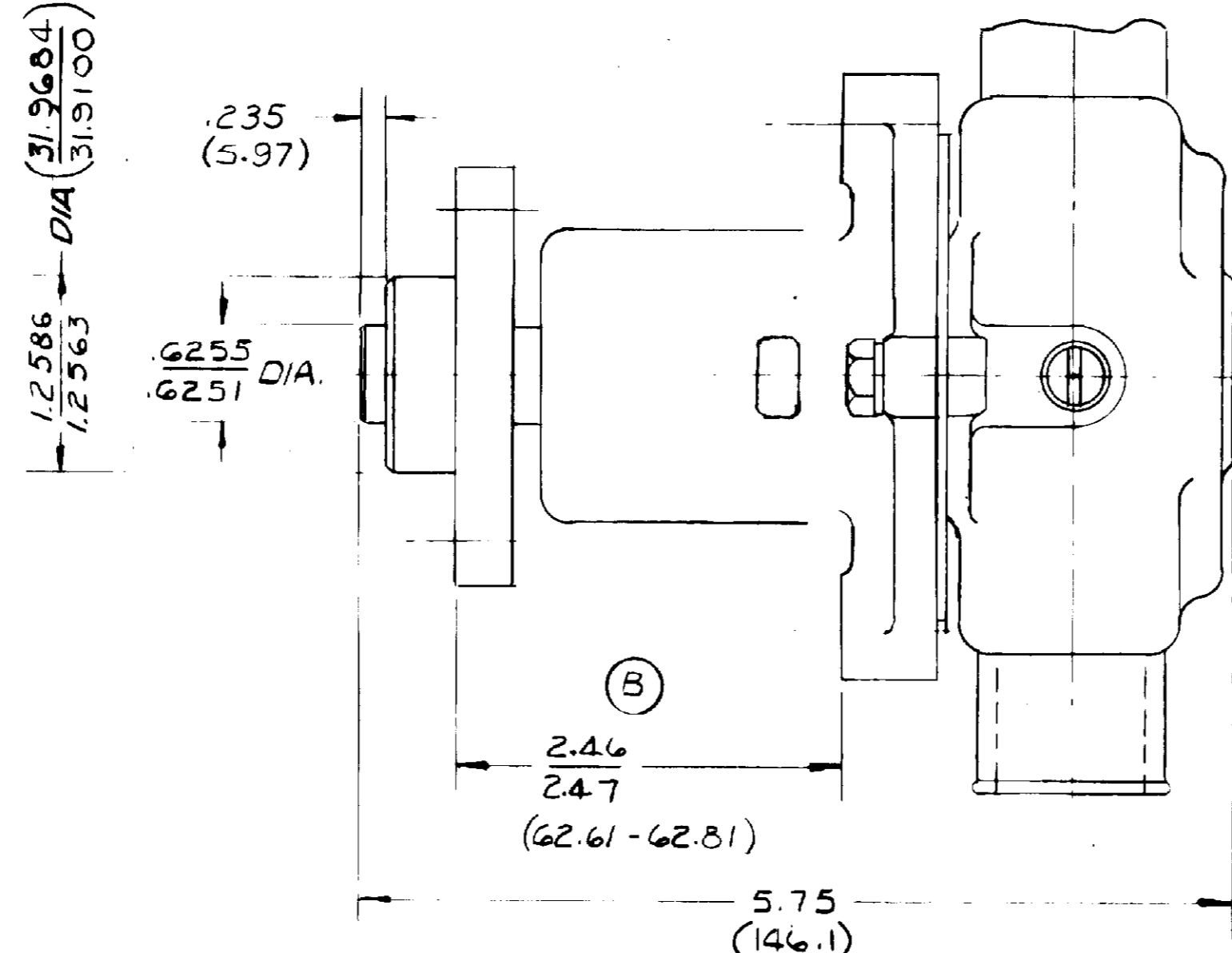

PACKAGING:
 N° 17659 CARTON Y
 12209 LABEL
 17653 JIFFY BAG #5

1 REQ'D.
 1 REQ'D
 1 REQ'D.

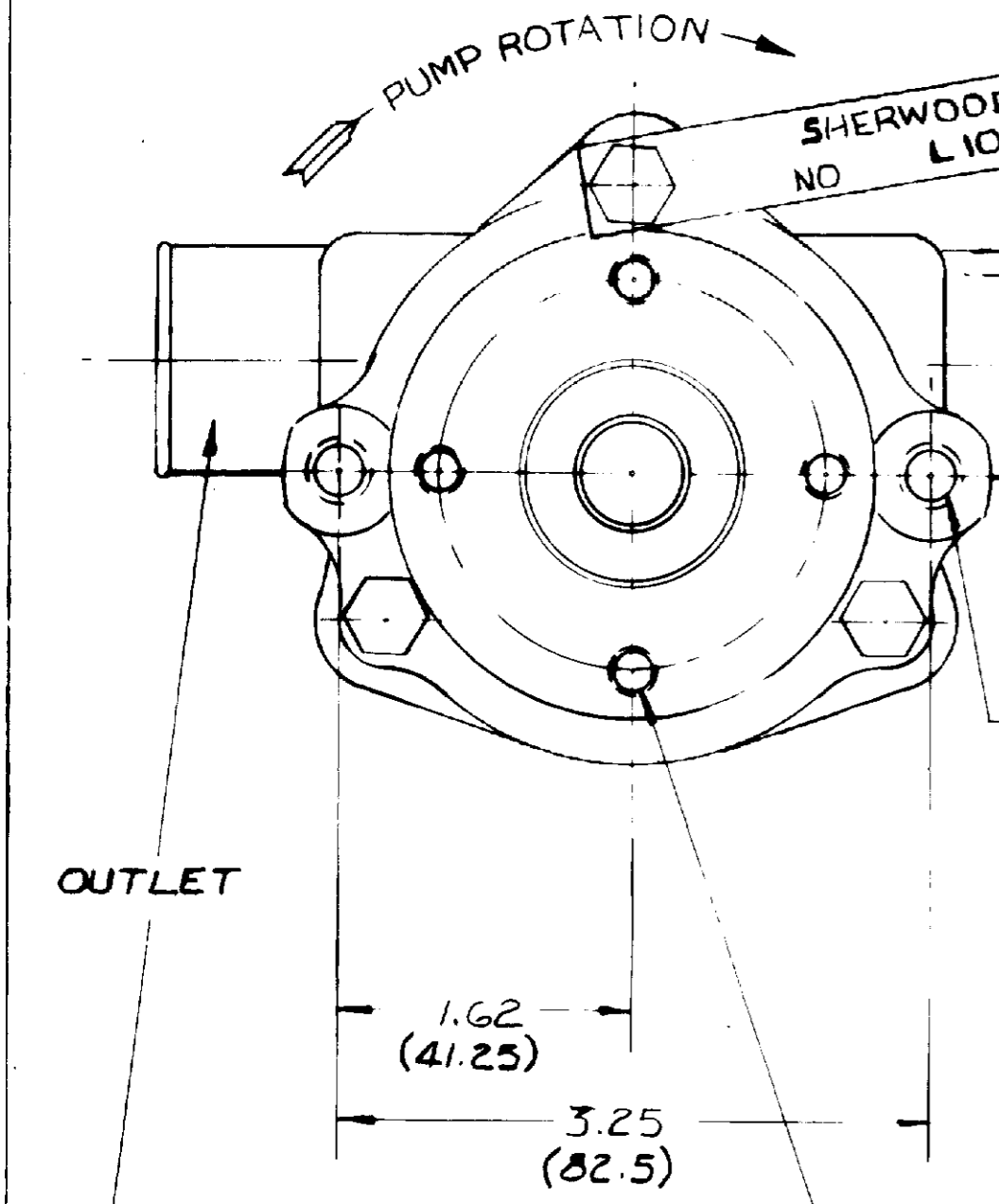

21 STAMP PUMP ASS'Y NO AND DATE CODE ON TAG AND ATTACH WITH SCREW TO THIS LOCATION

M8 X 1.25 THD 2 PLACES

TO PROVIDE MAXIMUM SHAFT TO HUB BREAK AWAY TORQUE. THE SHAFT MUST BE HELD SQUARE WITH THE PULLEY HUB WHEN THEY ARE PRESSED TOGETHER. SHEARING OF METAL WILL REDUCE BREAK AWAY TORQUE

M8 X 1.25 METRIC THD. 4 HOLES EQUALLY SPACED ON 2.125 BOLT CIRCLE

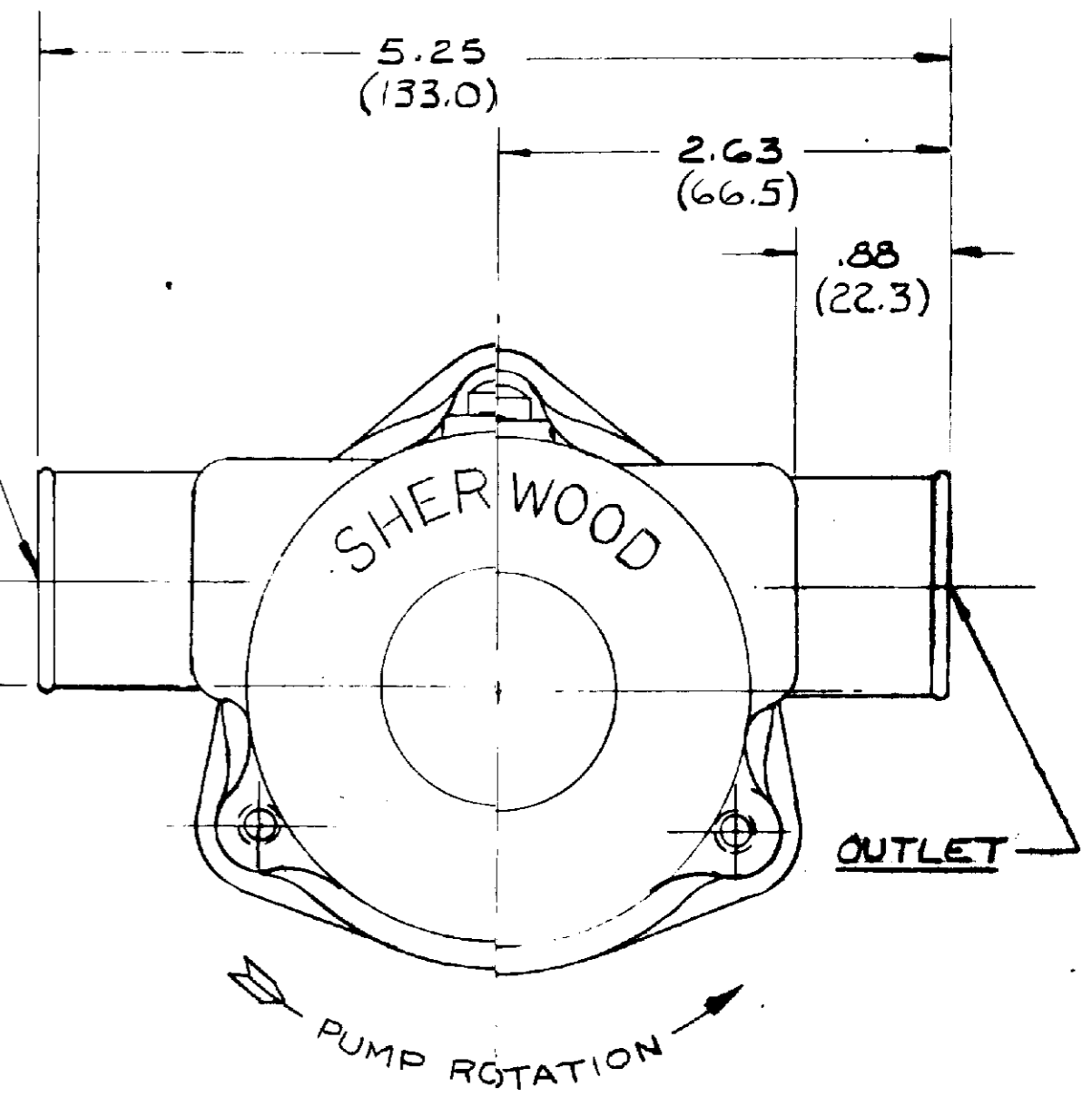
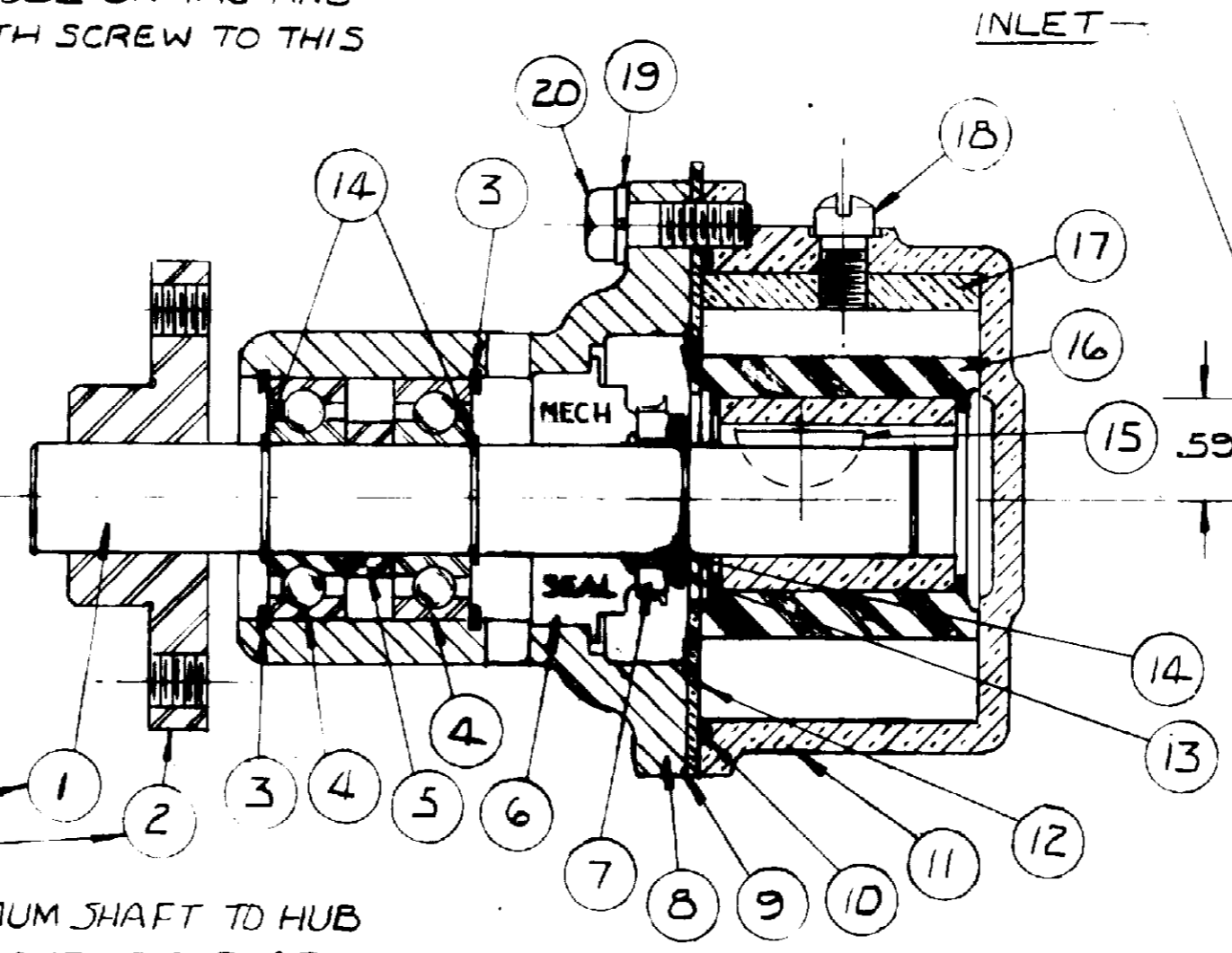

ONAN CORP No 132-0278
 CURVE No. 76004 R.

A PAINT THIS HOSE NIPPLE WITH RED PAINT AFTER TESTING - ONE PORT ONLY

REV	DESCRIPTION	APPR	DATE
E	12946 WAS 12872	SH	7/5/90
D	12859 WAS 12322	SH	7/5/90
C	12314 WAS 8388	SH	11-11-88
B	62.61-62.81 MM W/...	RM	8-30-88
A	PRINT NOTE AD...	RM	7-2-88

UNLESS OTHERWISE SPECIFIED TOLERANCE TO BE
 CAST DIMENSION ± .020
 MACHINED DIMENSION
 FRACTIONAL ± .010
 DECIMAL ± .008
 ANGLES ± 1/2°
 MACHINED SURFACE ROUGHNESS
 ALLOW 1/16 STOCK ON ALL FINISHED SURFACES FOR MACHINING.
 BREAK ALL SHARP EDGES .010 MAX
 CAST FILLETS AND RADII 1/16 R

SHERWOOD
 A DIVISION OF HYPRO CORPORATION
 6981 E. JEFFERSON AVE. - DETROIT, MICHIGAN 48207

DRAFTSMAN	DATE	CHECKER	DATE	REV NO
RBM	11-23-88			

TITLE: PUMP ASSEMBLY
 MATERIAL: SEE DETAIL
 DWG NO: L10

FROM 396